

Low profile magnetic drilling machine

ECO.36+T



Congratulations on purchasing this premium magnetic drilling machine. At EUROBOOR we strive to exceed our customers' expectations by developing and providing premium and innovative portable drilling and cutting solutions. We believe that a professional like you must be able to rely on a professional supplier. Which has led us to become a major player in the industrial world, with our own factory and several offices worldwide. All because we have always listened to our customers and to the demands from the market.

Our vision is focused on developing innovative portable tools that add value for our customers and facilitate them in their daily work. We never lose sight of sustainability, time savings and cost savings.

Enjoy your new machine!

Before operating your new magnetic drilling machine, please first read all instructions. You find the instructions in this manual and on the warning label on your machine. With proper use, care and maintenance your machine will provide you with years of premium drilling performance.

TO REDUCE THE RISK OF INJURY USER MUST READ AND UNDERSTAND ALL INSTRUCTIONS

To view all our offices and their contact information please visit: www.euroboor.com

The original manual has been produced in the English language. If any discrepancies should occur in translations, reference must be made to the original version for clarification.

Table of contents

ECO.36+/T.....	1
Table of contents	3
1. Safety.....	4
1.1 General safety instructions	4
1.2 Specific safety information.....	6
2. Description.....	8
2.1 Intended use.....	8
2.2 Description and features	8
2.3 Case content.....	9
2.4 Serial number	9
2.5 Technical data.....	10
2.6 Symbols	10
2.7 Environmental	11
3. Preparation & adjustment	12
3.1 Assembly	12
3.2 Prior to use	18
4. Using the machine	19
4.1 Carrying handle	19
4.2 Control panel.....	20
4.3 2-Way electromagnet.....	20
4.4 Switching motor on and off.....	21
4.5 Motor rotation	21
4.6 Motor speed control	22
4.7 GYRO-TEC safety.....	22
4.8 Power protection.....	22
4.9 Carbon brushes	23
4.10 Tool lubrication	24
5. Working with drilling accessories	25
5.1 Annular cutters.....	25
5.2 Twist drills.....	27
5.3 Machine taps	27
5.4 Countersinks.....	28
6. Maintenance	29
7. Trouble shooting	31
8. Exploded views & spare parts list	33
8.1 Exploded views	33
8.2 Spare parts list.....	35
8.3 Wiring diagram	38
8.4 Warranty and service	39

1. Safety

1.1 General safety instructions

Do not use this magnetic drilling machine before you have thoroughly read and completely understood this manual, specifically the “General safety instructions” and “Specific safety information”, including the figures, specifications, safety regulations and the signs indicating DANGER, WARNING and CAUTION.



WARNING: When using electrical tools basic safety precautions should always be followed to reduce the risk of fire, electrical shock and personal injury.

Please also observe the relevant national industrial safety regulations. Non-observance of the safety instructions can lead to an electric shock, burns and/or severe injuries.

This manual should be kept for later use and enclosed with the magnetic drilling machine, should it be passed on or sold.

Work area

1. Keep your work area clean and well lit. Cluttered and dark work areas increase the chance of accidents;
2. Do not operate a magnetic drilling machine in explosive atmospheres, such as in the presence of flammable liquids, gases or dust. A magnetic drilling machine may create sparks which could ignite the dust or fumes;
3. Keep bystanders, children and visitors away while operating a magnetic drilling machine. Distractions can cause you to lose control.

Electrical safety

1. A magnetic drilling machine plug must match the outlet. Never modify the plug in any way. Do not use any adapter plugs;
2. Avoid body contact with grounded surfaces such as pipes, radiators, ranges and refrigerators. There is an increased risk of electric shock if your body is grounded;
3. Do not expose the magnetic drilling machine to rain or wet conditions. Water entering a machine will increase the risk of electric shock;
4. Do not abuse the power cable. Never use the cable to carry the magnetic drilling machine or pull the plug from an outlet. Keep the cable away from heat, oil, sharp edges or moving parts. Replace damaged cables immediately. Damaged cables increase the risk of electric shock;
5. When operating a magnetic drilling machine, use an extension cable suitable for outdoor use, this reduces the risk of electric shock;
6. If operating a magnetic drilling machine in a damp location is unavoidable, use a residual current device (RCD), this reduces the risk of electric shock.

Personal safety

1. Stay alert, watch what you are doing and use common sense when using a magnetic drilling machine. Do not use the machine while tired or under the influence of drugs, alcohol, or medication. A moment of inattention while operating a magnetic drilling machine may result in serious personal injury;
2. Dress properly. Do not wear loose clothing or jewelry. Keep your hair, clothing and gloves away from moving parts. Loose clothes, jewelry or long hair can be caught in moving parts;
3. Avoid accidental starting. Be sure the switch is off before plugging the machine in. Carrying a magnetic drilling machine with your finger on the switch or plugging in a magnetic drilling machine that has the switch on increases the change of accidents;
4. Never place hands, fingers, gloves or clothing near drilling area or rotating machine parts.
5. Remove adjusting keys or switches before turning the machine on. A wrench or a key that is left attached to a rotating part of the machine may result in personal injury;
6. Do not overreach. Keep proper footing and balance at all times. Proper footing and balance enables better control of the magnetic drilling machine in unexpected situations;
7. Use safety equipment. Always wear eye protection. Dust mask, non-skid safety shoes, hard hat and hearing protection must be used for optimal safety;
8. Always use supplied safety strap during any work on non-horizontal surfaces. Magnetic drilling machine can release from surface;



WARNING: *Wear ear and eye protection when using this machine.*

Machine use and care

1. When using the machine on non-horizontal surfaces, you must use cutting paste. Do not use oil because the oil can drip into the motor unit;
2. While operating the machine, the annular cutter must be cooled and lubricated with high quality cutting lubricants;
3. Always remove the slug from the annular cutter after each hole.



WARNING: *The metal slug can be sharp and very hot!*

4. Use clamps or other practical solutions to secure and support the workpiece to a stable platform. Holding the workpiece by hand or against your body is unstable and may lead to loss of control;
5. Do not use the machine when the switch does not turn it on or off. Any machine that cannot be controlled with the switch is dangerous and must be repaired;
6. Disconnect the plug from the power source before making any adjustments, changing accessories or storing the tool. Such preventive safety measures reduce the risk of starting the tool accidentally;
7. Store your magnetic drilling machine out of reach for children and other untrained persons. Tools are dangerous in the hands of untrained users;
8. Maintain your machine with care. Keep cutting tools sharp and clean. Properly maintained tools, with sharp cutting edges are less likely to break and are easier to control;
9. Check for misalignment of moving parts, breakage of parts and any other condition that may affect the machine's operation. If you detect damage have the machine serviced before use. Many accidents are caused by poorly maintained tools;
10. Only use accessories that are recommended by EUROBOOR for your machine model. Accessories that are suitable for one machine may become hazardous when used on another machine.

Service

1. Tool service must be performed only by qualified repair personnel. Service or maintenance performed by unqualified personnel could result in risk of injury;
2. When servicing a tool, use only identical replacement parts. Follow instructions in the maintenance section of this manual. Use of unauthorised parts or failure to follow maintenance instructions may create a risk of electric shock or injury;
3. EUROBOOR offers kits containing genuine EUROBOOR spare parts suitable for your magnetic drilling machine.

1.2 Specific safety information

- Keep your fingers away from the drilling area;
- Avoid touching the slug that is automatically ejected by the pilot pin when the working procedure is finished. Contact with the slug when it is hot, or if it falls, can cause personal injuries;
- Always use the safety guard. Before switching on the machine ensure that the guard is closed securely;
- Always use the safety strap;
- The magnetic drilling machine is suitable for use on steel with a thickness starting from 6 mm, with zero air gap between the magnet core surface and the mounting surface. Curvature, coats of paint and surface irregularities will create an air gap. Keep the air gap to a minimum;
- Always place the machine on a flat surface;
- Do not clamp the magnetic drilling machine on small or irregular shaped objects;
- Always place the machine on a surface that is clear of shavings, chips, swarf and surface dirt;
- Keep the magnet clean and free of debris and swarf;
- Do not switch on the machine before checking whether the magnetic stand has been tightened firmly to the mounting surface;
- Adjust the machine so cutter does not extend into the workpiece before drilling. Do not perform any design, assembly or construction activities on the workpiece while the machine is switched on;
- Before switching on the machine, make sure all accessories have been mounted correctly;
- Do not switch on the machine until it has been mounted and installed according to all above mentioned instructions;
- Always use the recommended speed for the accessories and material you are working with;
- Do not use the machine on the same workpiece on which electric welders are working;
- Only use an appropriate cutting lubricant. EUROBOOR offers a wide range of well-considered cooling and lubrication products to match your requirements;
- Do not use liquid cutting fluids while drilling vertically or overhead. Dip the cutter in cutting paste or apply an appropriate spray for these applications;
- Do not pour cutting fluid into the reservoir while it is mounted in the bracket. Do not allow cutting fluid to enter the drill motor;
- Before use, ensure movable safety guard operates properly;
- In case of a jammed cutter, turn off the machine, disconnect the machine from the power supply and then remove the reason for the jam before turning on the machine again.

Residual risk

In spite of following the relevant safety regulations and their implementation, certain residual risks cannot be avoided. These are:

- Impairment of hearing;
- Risk of personal injury from flying particles;
- Risk of burns due to accessories becoming hot during operation;
- Risk of personal injury due to prolonged use.

Always try to reduce these risks as much as possible.

2. Description

2.1 Intended use

This magnetic drilling machine is intended for commercial use as a drilling machine for drilling materials with a magnetisable surface using annular cutters and twist drills, tapping and for countersinking in a weather-protected environment using the application tools and accessories recommended by EUROBOOR. The magnetic drilling machine can be used horizontally, vertically or overhead.

2.2 Description and features

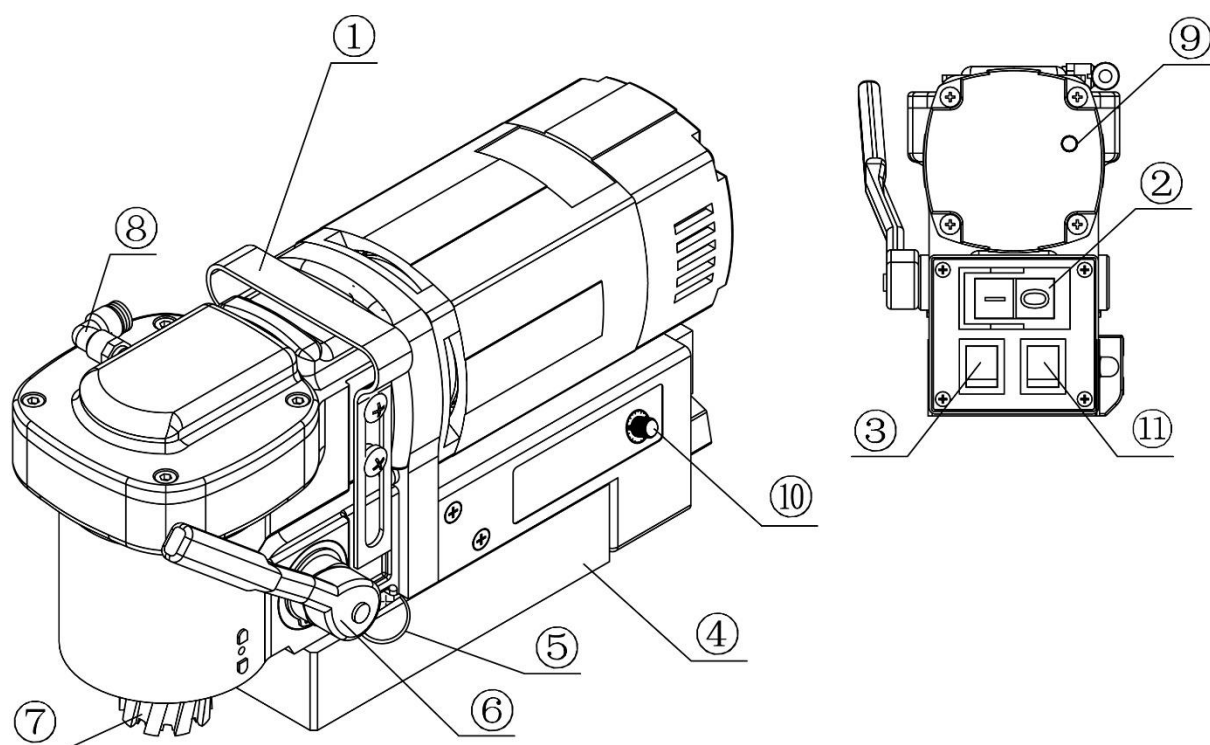

[image 2-1]

1	Carry handle	7	Output shaft
2	Motor switch	8	Cutter lubrication connector
3	L/R rotation switch	9	Carbon brush LED indicator
4	Electromagnet	10	Speed control knob (potentiometer)
5	Ring for safety strap	11	Magnet switch
6	Ratchet feed handle		

2.3 Case content

- 1 x ECO.36+/T Magnetic drilling machine
- 1 x safety guard
- 1 x ratchet feed handle
- 1 x hex key 3 mm
- 1 x hex key 4 mm
- 1 x lubrication system
- 1 x safety strap
- 1 x bottle (200 ml) of IBO.10 cutting oil
- 1 x user manual
- 1 x safety ear protection
- 1 x safety goggles
- 1 x safety gloves

2.4 Serial number

The serial number is mentioned on the machine three times: engraved on the frame, engraved on the magnet and on the serial no. sticker on the motor housing. Additional serial no. stickers are provided with the machine for your administration.

The serial number will help you, your dealer and EUROBOOR to validate and identify the machine.

For example:

0362004001

breaks down to:

036 20 04 001

Machine series

Year of manufacture

Month of manufacture







Identification number





2.5 Technical data

	Metric	Imperial
Annular cutting	∅ 12 - 36 mm	∅ 7/16" - 1 7/16"
Twist drilling	∅ 1 - 14 mm	∅ 1/16" - 9/16"
Tapping	M3 - M12*	∅ 1/8" - 3/8"
Countersinking	∅ 10 - 40 mm	∅ 3/8" - 1 9/16"
In-corner drilling (centre to edge)	0° = 50 mm	0° = 1 31/32"
	45° = 60 mm	45° = 2 23/64"
	90° = 53 mm	90° = 2 3/32"
Length	310 mm	12 3/16"
Width	135 mm	5 5/16"
Height	165 mm	6 1/2"
Stroke	40 mm	1 9/16"
Weight	10.3 kg	22.7 lbs
Magnet (l x w x h)	160 x 80 x 37 mm	6 5/16" x 3 1/8" x 1 7/16"
Magnetic force	1,200 kg	2,650 lbs
Motor power	1,050 W	8.5 A
Total power	1,100 W	9 A
Speed (no load)	120 - 500 rpm	120 - 500 rpm
Speed (load 1,050 W / 8.5A)	400 rpm	400 rpm
Spindle (Weldon)	19.05 mm	3/4"
Voltage	220 - 240 V / 50 - 60 Hz	110 - 120 V / 60 Hz

*For tapping M12 threads, we recommend pre-drilling with a diameter of 10.5 mm.

2.6 Symbols

Symbol	Term, meaning	Explanation
	Read documentation	Be sure to read the documentation in this user manual and specifically the "General safety instructions" and "Specific safety information".
	Wear ear protection	Use ear protection during operation.
	Wear eye protection	Use eye protection during operation.
	Danger/warning/caution	Read and apply the information in the adjacent text!
	European conformity symbol	Confirms the conformity of the magnetic drilling machine with the directives of the European Community.
	Class of protection I	Product with basic insulation and exposed (touchable) conductive parts additionally connected to the protective earth conductor.
	Electromagnetic Compatibility	Able to function acceptably in its electromagnetic environment.

Symbol	Term, meaning	Explanation
	ETL	Compliant to North American safety standards via Electrical Testing Laboratories (ETL), the certification division of Intertek
	International Electrotechnical Commission	Conformity with international electrotechnical safety standards.
	ISO9001	Certified in accordance with ISO9001:2015 quality management system.
	UL	Certified by Underwriters Laboratories (UL), a recognised laboratory for safety testing approved by US federal agency OSHA.
mm	Millimetre	Unit of measure for the dimensions.
"	Inch	Unit of measure for the dimensions.
kg	Kilogram	Unit of measure for the mass.
lbs	Pound	Unit of measure for the mass.
V	Volt	Unit of measure for the electric voltage.
A	Ampere	Unit of measure for the electric current intensity.
W	Watt	Unit of measure for the output.
rpm	Revolutions per minute	Unit of measure for the revolutions.
no	No load speed	Revolution speed at no load.

2.7 Environmental



Separate collection. This product must not be disposed of with normal household waste.



Separate collection of used products and packaging allows materials to be recycled and used again. Re-use of recycled materials helps prevent environmental pollution and reduces the demand for raw materials.

Local regulations may provide for separate collection of electrical products from the household, at municipal waste sites or at the retailer when you purchase a new product.

3. Preparation & adjustment

3.1 Assembly

 **WARNING:** To reduce the risk of injury, turn machine off and disconnect from power source before installing and removing accessories, before adjusting or changing set-ups or when making repairs. Be sure all switches are in the OFF position. An accidental start-up can cause injury.

Fitting the feed handle

1. Take the ratchet feed handle, and line the square up with the square opening in the machine feed axle (image 3-1);
2. Push the ratchet feed handle in the machine feed axle while pressing the release button on the ratchet feed handle (image 3-3). You can place the feed handle in a position that best matches your drilling set-up;
3. To change the rotation direction of the ratchet feed handle, you can switch the small lip on the ratchet feed handle (image 3-2):
 - a. To move the ratchet feed handle in clockwise direction, switch the lip to the left;
 - b. To move the ratchet feed handle in counter clockwise direction, switch the lip to the right;

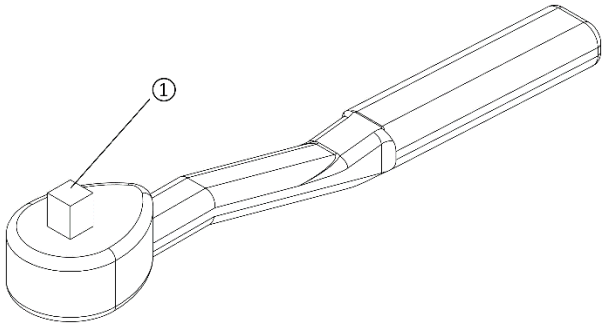

[image 3-1]

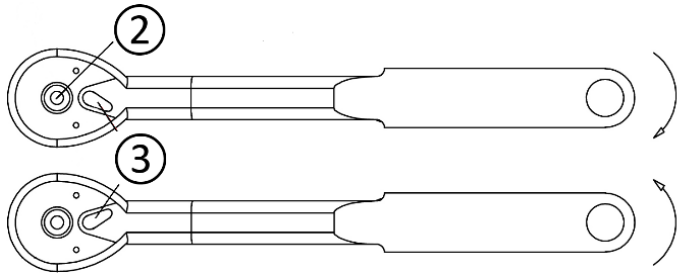

[image 3-2]

4. To release the ratchet feed handle from the machine, press the release button on the ratchet feed handle and pull it away from the machine;

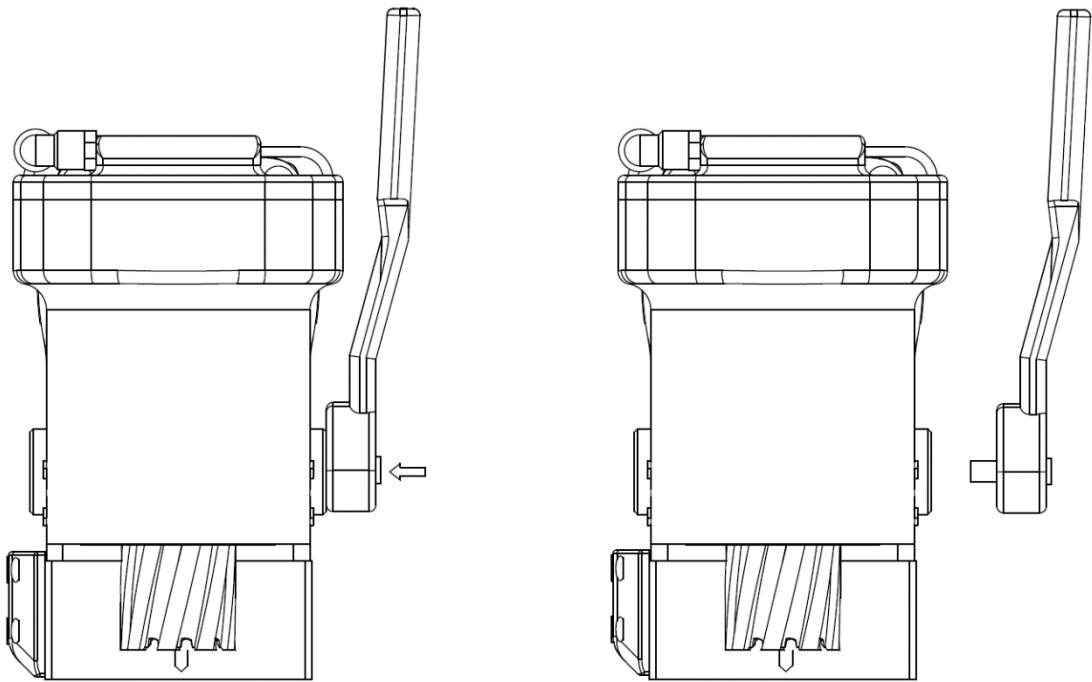

[image 3-3]

5. It is possible to position the ratchet feed handle on either side of the machine. Method of fitting and releasing (steps 1. to 4.) is always the same.

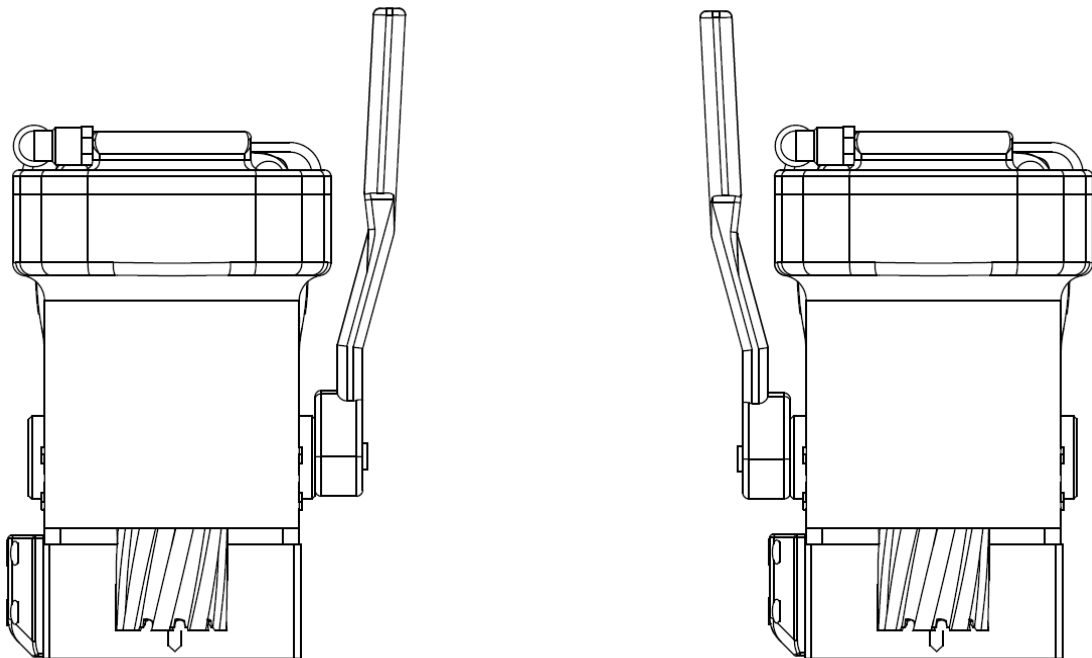

[image 3-4]

Mounting the safety guard

The safety guard protects against chippings and accidental contact and must always be mounted before operation.

1. Place the drill guard in front of the machine. Make sure the long slots on the side clip over the small humps protruding from the gearbox body.
2. Fit the two thumbscrews in the designated holes, and tighten by hand. Make sure the drill guard is fitted firmly, but don't overtighten the screws.

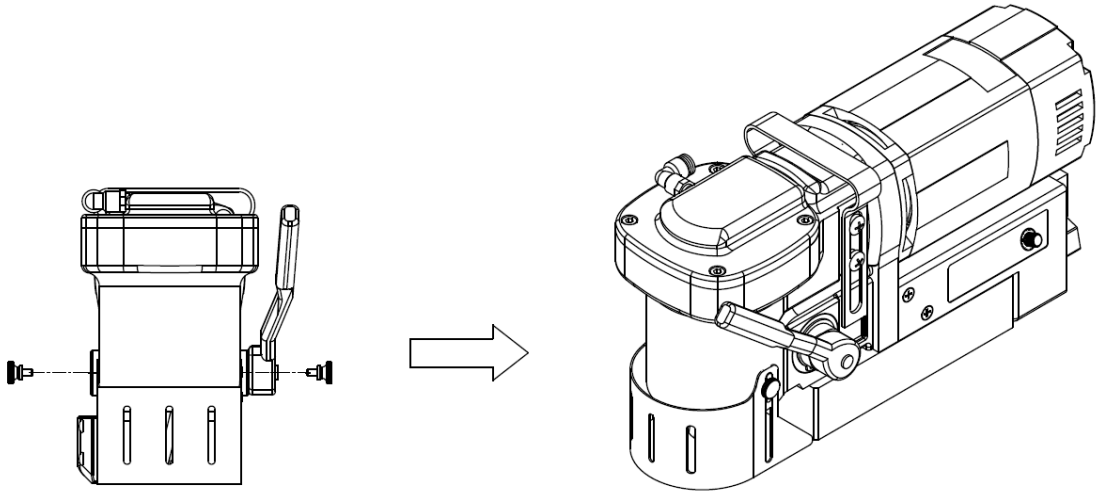

[image 3-5]



WARNING: Always use the safety guard.

Fitting the lubrication system

The lubrication system can only be used for horizontal drilling (the drill being used vertically).

- 1. The lubrication tank is equipped with an extra-long hose. This hose can be cut to the desired length;
- 2. The tank is equipped with a magnet at the back. This makes it possible to place the tank against any ferro product;

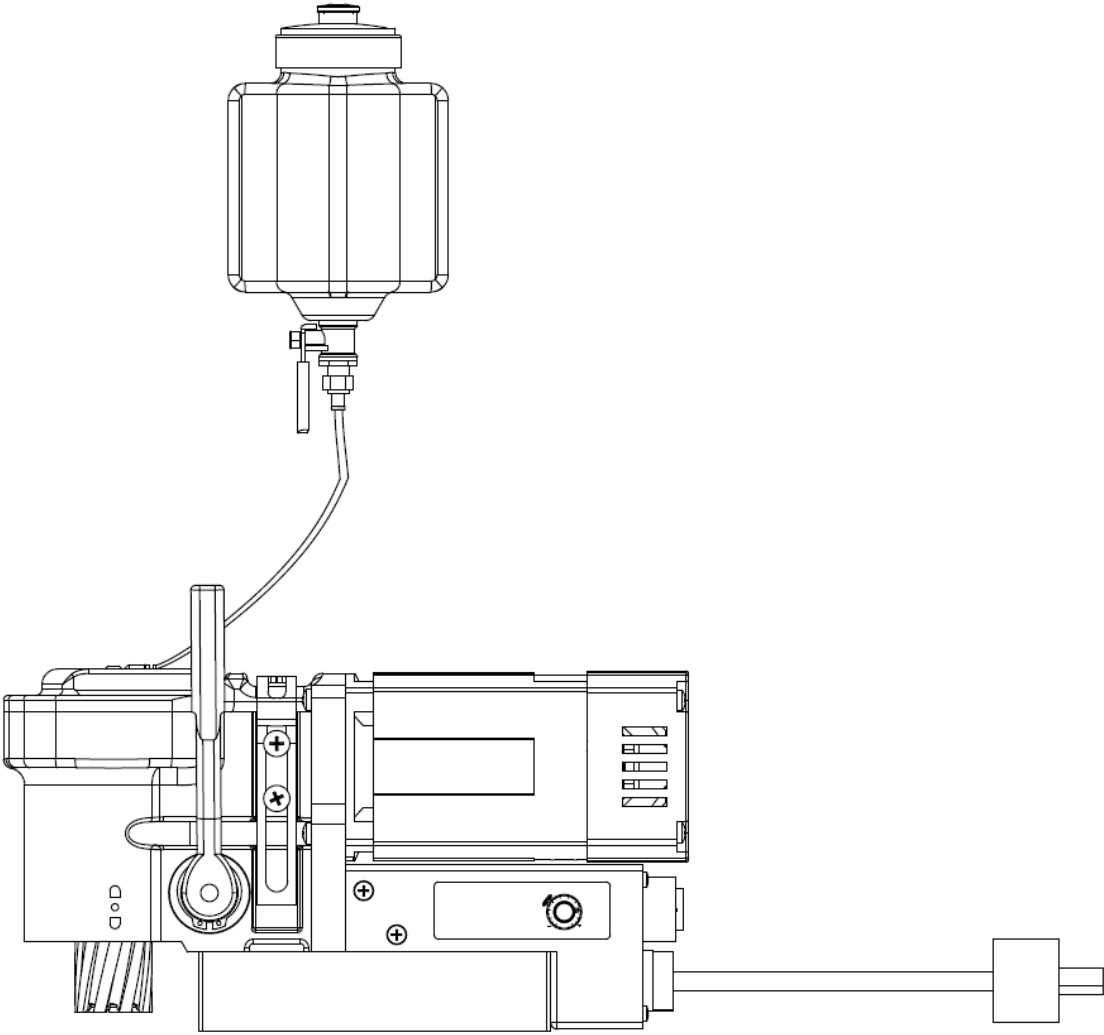

[image 3-6]

3. Connect the hose to the magnetic drilling machine by pushing it firmly into the connector on the machine;

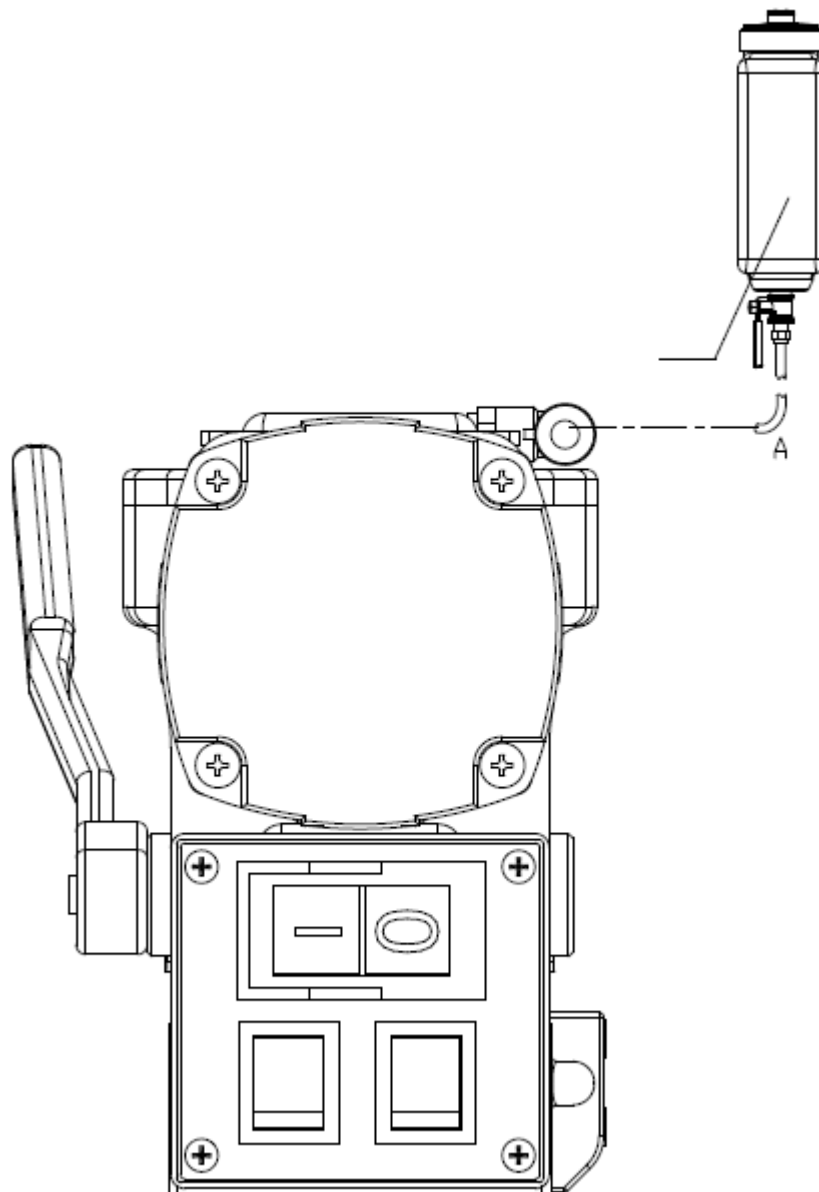

[image 3-7]

4. To disconnect the hose, press the blue ring on the connector and gently pull out the hose.

In order to use the lubrication system, it must be filled with a sufficient amount of cutting fluid.

1. Make sure the flow regulator is closed;
2. Unscrew the cap;
3. Fill the container with cutting fluid;
4. Screw the cap back on.



WARNING: Do not use the lubrication system in vertical or overhead drilling applications. Instead use EUROBOOR spray or cutting paste.

Fitting the safety strap

The safety strap should always be used during operation. Use of the safety strap limits the risk of personal injury when for some reason the magnet comes loose from the workpiece (such as loss of power supply). In no way does the use of the safety strap clear the operator from following other safety and operating instructions.

The safety strap can be used in two different ways:

1. On a narrow workpiece you can loop the strap through the two D-rings and underneath the workpiece . Pull the strap through its buckle and make sure the strap is tight all-around;

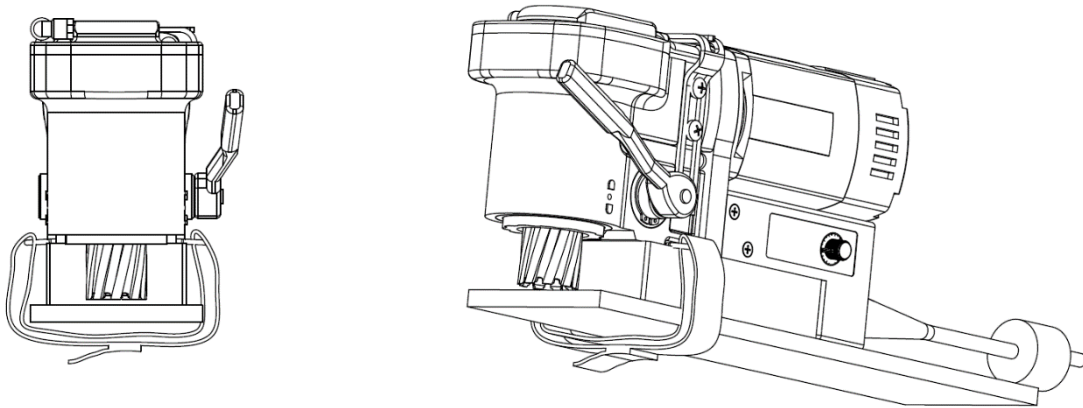

[image 3-8]

2. On a larger workpiece you can loop the strap trough one D-ring and an available opening in the workpiece itself. Pull the strap through its buckle and make sure the strap is tight all-around.

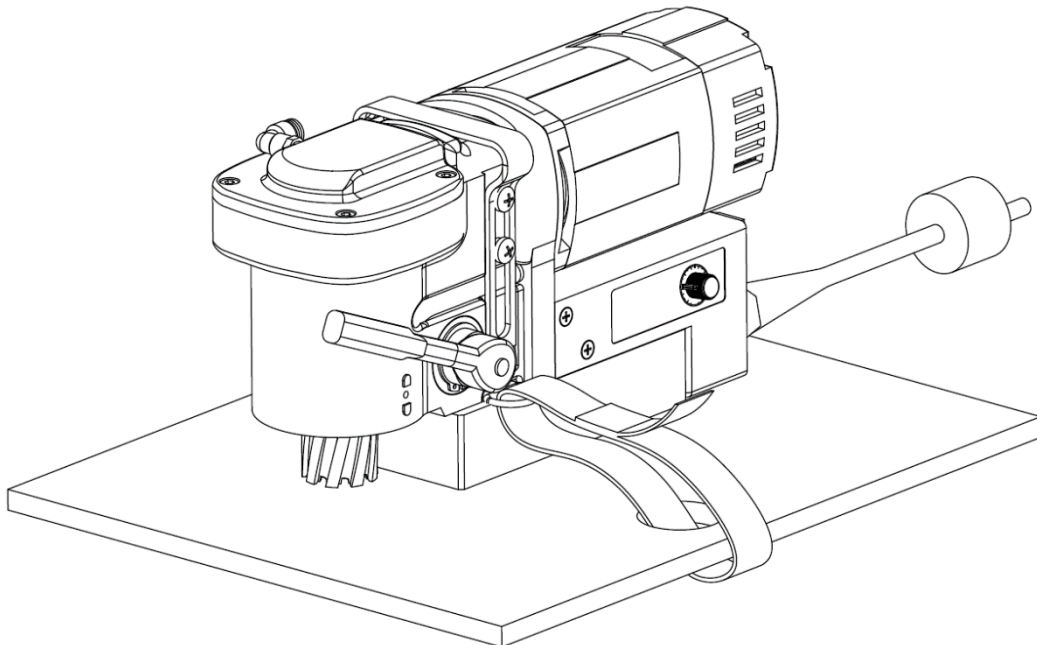

[image 3-9]



WARNING: Always use the safety strap when drilling vertically and/or up-side-down. The safety strap does not replace the magnetic force of the magnetic drilling machine: it is simply used to secure against falling in the event of a magnet malfunction.

3.2 Prior to use

Please make sure that the contacting surface for the magnet is level, clean and rust free. Remove any varnish or primer. When working on materials that are not magnetisable, suitable fixation devices, obtainable as accessories from EUROBOOR, e. g. suction plate, vacuum plate or pipe-drilling machine must be used.

When working on steel materials with a material thickness of less than 6 mm, the workpiece must be reinforced with an additional steel plate in order to guarantee the magnetic holding power.

Check the machine for possible damage; Before using the machine, you must carefully check the protective components or slightly damaged components to ensure they are operating perfectly and as intended.

Check that moving parts are in perfect working order, do not jam and check whether the parts are damaged. All parts must be correctly installed and fulfill all conditions necessary to ensure perfect operation of the machine.

Damaged protective components must be repaired or replaced according to specifications by EUROBOOR or any authorised EUROBOOR dealer.

DO NOT use under wet conditions or in presence of flammable liquids or gases.

DO NOT let children come into contact with the machine. Supervision is required when inexperienced operators use this machine.

Electrical safety

The electric motor has been designed for one voltage only. Always check that the power supply corresponds to the voltage on the rating plate.

Your EUROBOOR magnetic drilling machine is designed in class I (grounded) according to EN 61029-1. Earth wire is required.

If the power cable is damaged, it must be replaced by a specially prepared cable available at EUROBOOR or your EUROBOOR dealer.

Extension cable

If an extension cable is required, use an approved 3-core extension cable suitable for the power input of this machine (see technical data). The minimum conductor size is 1.5 mm²; the maximum length is 30 meter. When using a cable reel, always unwind the cable completely.

Useful tips

- Try a few simple projects using scrap material until you develop a “feel” for the magnetic drilling machine;
- Let the machine run in for a period of eight to ten hours before starting with big operations. Do not load the machine too much during this run-in period;
- Never use the machine with serious overload;
- Keep the machine clear from moisture at all times to protect the machine, yourself and others.

4. Using the machine



WARNING: Always observe the safety instructions and applicable regulations.



WARNING: To reduce the risk of serious personal injury, turn the machine off and disconnect the machine from power source before making any adjustments or removing/installing attachments or accessories.

4.1 Carrying handle

This machine is designed to be carried by hand only, with the use of the integrated retractable carrying handle. Always check if the 4 screws holding the carrying handle in place are still firmly tightened prior to carrying the machine.

- 1) To extract the carrying handle, gently pull it up at both ends simultaneously (image 4-1);
- 2) The machine should be carried with one hand only, with 4 fingers (all other than the thumb);
- 3) To retract the carrying handle, gently push it down. Be careful not to get any body parts stuck.

It is advised to have the carrying handle retracted during operation, as it increases clearance around the machine.

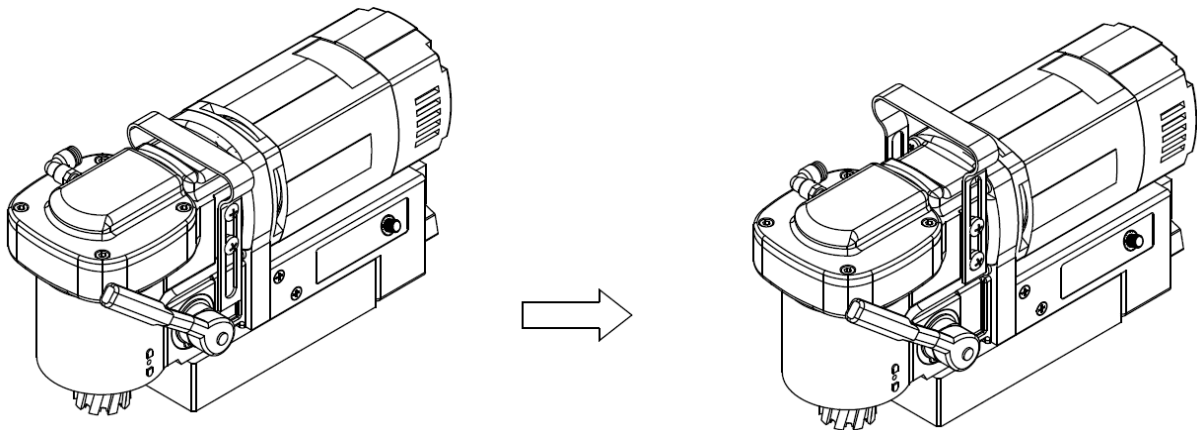

[image 4-1]

4.2 Control panel

The control panel on your magnetic drilling machine is designed for maximum ease of use and safety.

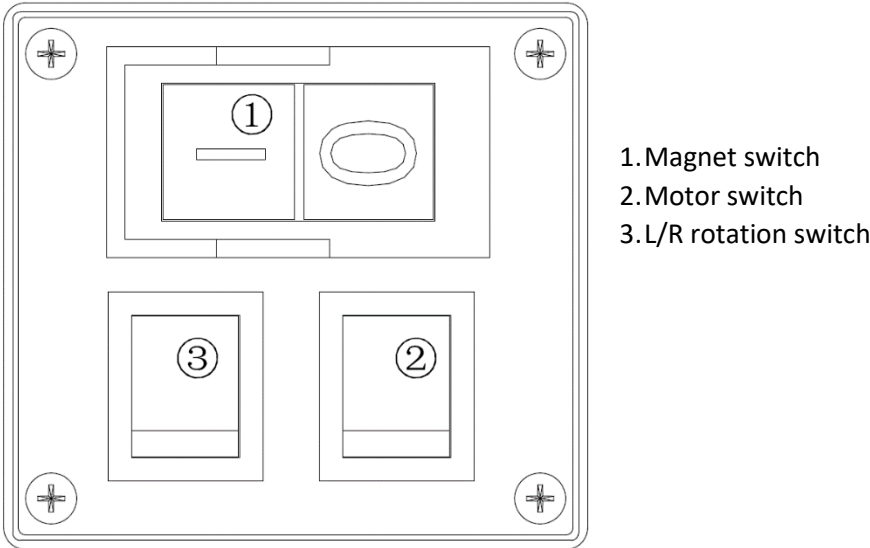

4.3 2-Way electromagnet

Make sure the magnetic drilling machine is placed on a smooth, clean, level and solid surface without any objects or debris to guarantee maximum adhesion.

The workpiece must at least be 6 mm (1/4") thick for the magnet to stick and to drill safely. In case the workpiece is between 3 mm (1/8") and 6 mm (1/4") make sure to make a proper base to create a good magnetic field as shown below.

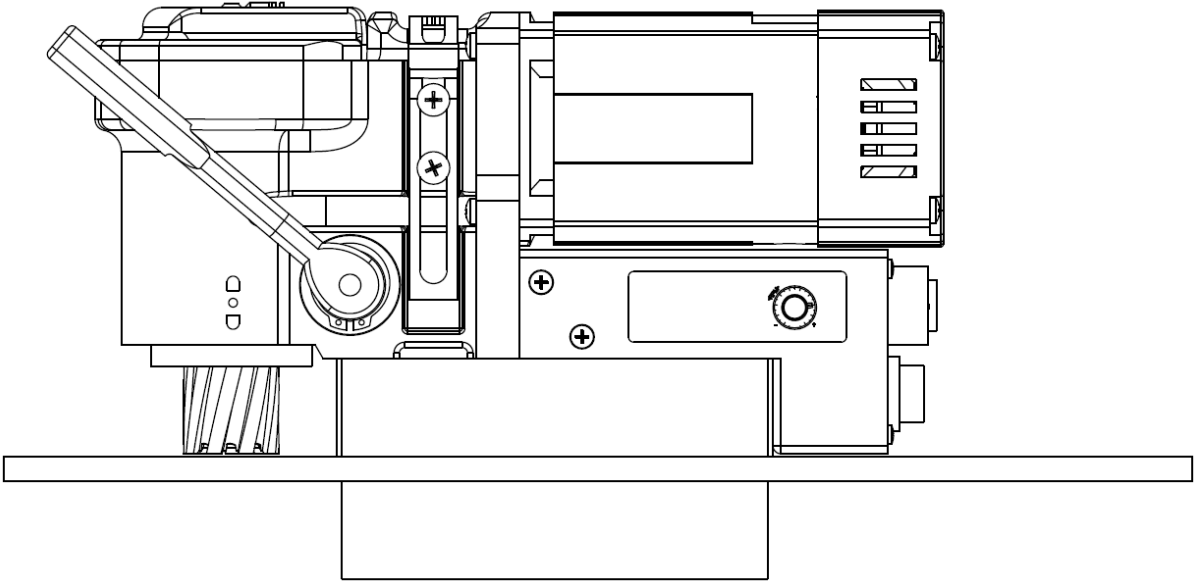

[image 4-3]

The electromagnet will work best on surfaces of at least 10 mm (3/8") thickness.

When the electromagnet is not able to create a good enough magnetic field, this may be caused by:

- Surface not being flat;
- Workpiece is not magnetisable (e.g. aluminium);
- Workpiece is coated or painted;
- Workpiece is not thick enough.

Make sure to solve any of these matters before proceeding in any way and creating unsafe situations.

2-Way magnet

This machine is equipped with a 2-way magnet function. At half of the magnetic force (600 kg \approx 1,325 lbs), the magnet sufficiently sticks to the surface to hold the machine in position while not in use. More importantly, it consumes less energy, generates less heat and as a consequence will last longer. Only with full magnetic force (1,200 kg \approx 2,650 lbs) the machine can be used for drilling.

Using the 2-way magnet:

1. Place and position the machine on the workpiece;
2. To activate the magnet at half of the magnetic force, press the RED magnet switch. The magnet switch will be lit (RED);
3. For full magnetic force, press the GREEN motor switch (see next paragraph);
4. To deactivate the magnet, first press the RED motor switch to return to half magnetic force and then press the magnet switch again.

We want to point out that above mentioned precautions do not guarantee that the magnet will not release from the material. EUROBOOR accepts no liability when it comes to the magnet not functioning or functioning poorly.

Make sure that the magnet attaches tightly to the work piece before turning on the motor unit of the magnetic drilling machine. EUROBOOR magnets have two coils; make sure that both coils are in contact with the material. Do not connect any other machine to the same electrical outlet to which the magnetic drilling machine is plugged into, as it may result in the loss of magnetic force.

Always use the safety strap included. Drilling above your head is extremely dangerous and is not recommended. For the use of magnetic drilling machines on pipes, not-flat or non-magnetic materials, we refer to our catalogue or our website www.euroboor.com where several vacuum tightening systems, pipe clamping systems and Tube machines can be found.

4.4 Switching motor on and off

The motor unit can only be switched ON when the magnet is activated. To switch the motor ON, press the green button with marking "I". To switch the motor OFF, press the red button with marking "O".

4.5 Motor rotation

The rotational direction of the motor can be changed:

- Switch in up position (R) will make the motor rotate clockwise;
- Switch in down position (L) will make the motor rotate counter clockwise;

Before switching the rotational direction of the motor and spindle, make sure the motor is switched OFF first, to prevent machine and tool damage.

4.6 Motor speed control

The speed control knob (potentiometer) allows you to electronically control the speed of the motor (in both clockwise and counter clockwise direction):

- The indicator of the potentiometer in bottom left corner is minimum speed;
- The indicator of the potentiometer in bottom right corner is maximum speed;

Be careful not to overturn the knob.

4.7 GYRO-TEC safety

This EUROBOOR magnetic drilling machine is equipped with GYRO-TEC safety functionality. It features a gyroscopic sensor which detects acceleration and displacement in any direction. Whenever the machine recognizes a sudden or unwanted movement the motor will be shut down automatically by the machine's electronics. This safety functionality offers protection to the user in various circumstances, such as:

- Sudden loss of magnetic force while in operation;
- Excessive vibration caused by incorrect drilling procedure, worn-out cutting tools, etc;
- Sudden displacement of the workpiece to which the magnetic drilling machine is attached.

By the motor shutting down automatically, risk of damaging or hurting the machine, tools, workpiece and operator is reduced.

Every time the motor is started, the machines electronics need a moment to run a systems check and initiate the safety system. The GYRO-TEC safety feature engages 3 seconds after the motor is started.

It is very important to note that this functionality raises the safety level, but does not prevent the operator from using the machine incorrectly. The operator should always follow instructions described in this manual and take all necessary safety precautions.

4.8 Power protection

The power protection feature is two-fold; it consists of both power fluctuation protection and power surge protection. Special safety components built into the electronics of the machine make it more reliable in situations where power supply can be of varying quality due to factors:

- Around the workplace, for example caused by switching on high power or unreliable electrical devices, a broken circuit breaker or faulty wiring;
- Outside the workplace, for example caused by an instable power grid or lightning.

A machine with this feature is able to cope with standard rated voltage and frequency fluctuations ranging from:

- 110 Volt to 130 Volt and 45 Hz to 65 Hz, or
- 220 Volt to 240 Volt and 45 Hz to 65 Hz

reducing the probability of breakdown and minimising down-time and repair cost.

Power fluctuation protection

When the frequency is too high (above 65 Hz) or too low (below 45 Hz), the motor will not start. If the frequency of the power supply falls outside the range during your drilling job, the motor will shut off automatically. The machine will work again normally when the normal frequency has been restored.*

Power surge protection

Beyond the rated voltage, a machine with this feature is able to cope with voltage spikes up to 4,000 Volt (1-2 μ s)*. Depending on the height of the spike, it may be necessary to replace built-in fuses, the control unit or the power switch, but other valuable parts like the motor and magnet will be protected.

***Disclaimer: Euroboor is not liable for any damage caused to the machine due to electrical problems in the workplace. Above mentioned protection is not guaranteed in all cases of voltage spikes and/or frequency fluctuations. Euroboor accepts no liability when it comes to the power protection not functioning or functioning poorly.**

In the situation of the motor being shut off automatically as self-protection, you should:

- Shut off the magnet;
- Disconnect the machine from the power source;
- Fix the source of the problem, by either:
 - o Making sure the issues with the power source is fixed;
 - o Connect the machine to a different and reliable power source;
- Continue using the machine as described in this user manual.

4.9 Carbon brushes

This machine is equipped with carbon brushes with two protection features. The purpose of both features is to schedule timely service and avoid additional costs by unexpected downtime or unnecessary part replacement.

Carbon brush wear indicator

At the back end of the motor unit you will find an integrated LED light. Under normal circumstances this light is off. The LED light will start burning red when the carbon brushes are worn to a level where it is advised to replace them.

Actual remaining operating time depends on the use of the machine, but can be at least twelve operating hours. This makes it possible to schedule service of the machine and avoid unexpected downtime.

Automatic shut-off

As additional protection, when the carbon brushes are actually worn to a level where replacement is needed, the motor will shut off automatically. This prevents the armature from being damaged. During automatic shut-off, the carbon brush wear indicator is not lit.

For replacement of carbon brushes, see chapter 6. Maintenance.

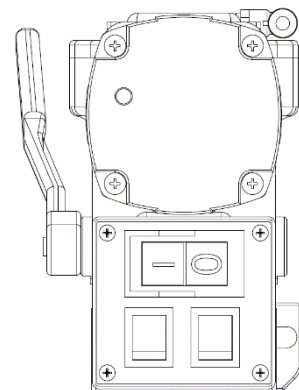

[image 4-4]

4.10 Tool lubrication

Horizontal applications

In order to use the lubrication system, the tank must be filled with a cutting lubricant:

1. Make sure the flow regulator is closed;
 2. Unscrew the cap;
 3. Fill the container with cutting lubricant;
 4. Screw the cap back on.
- Adjust the fluid flow as required using the flow regulator;
 - Add more cutting lubricant when the shavings (metal chips) become blue.

Vertical and overhead applications

Dip the cutter in cutting paste or apply an appropriate spray.



WARNING: *Do not use the lubrication system in vertical or overhead drilling applications. Instead use EUROBOOR cutting paste or spray.*

Make sure to use only suitable cutting lubricants. EUROBOOR offers a wide range of cutting lubricants for all tool and material combinations. Proper lubrication will help you create better and faster results, and extend the lifetime of your tools.

5. Working with drilling accessories

5.1 Annular cutters

Annular cutters only cut material at the periphery of the hole, rather than converting the entire hole to shavings. As a result, the energy required to make a hole is lower than for a twist drill. When drilling with an annular cutter, it is not necessary to drill a pilot hole.



WARNING: Do not touch the cutter or the parts close to the cutter immediately after operation, as they may be extremely hot and cause burns to the skin. Ensure nobody is in the work area where the metal core (slug) is ejected.

Drilling conditions

The ease with which material can be drilled depends on several factors including tensile strength and abrasion resistance. Whilst hardness and/or strength is the usual criterion, wide variations in machinability can exist among material showing similar physical properties.

The drilling conditions are dependent on requirements for tool life and surface finish. These conditions are further restricted by the rigidity of the tool and the workpiece, lubrication and machine power available. The harder the material, the lower the cutting speed.

Some materials of low hardness contain abrasive substances leading to rapid cutting edge wear at high speeds. Feed rates are governed by rigidity of set-up, volume of material to be removed, surface finish and available machine power.

Drilling a hole

Now that you have read the information and safety recommendations above, you are ready to actually start drilling. Follow these 13 steps for best drilling result:

- 1. Install the annular cutter:
 - Place the pilot pin into the cutter;

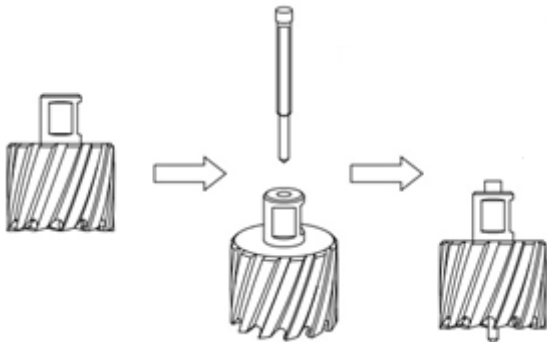

[image 5-1]



WARNING: Make sure the machine is still disconnected



WARNING: Always protect your hands against the sharp cutter!

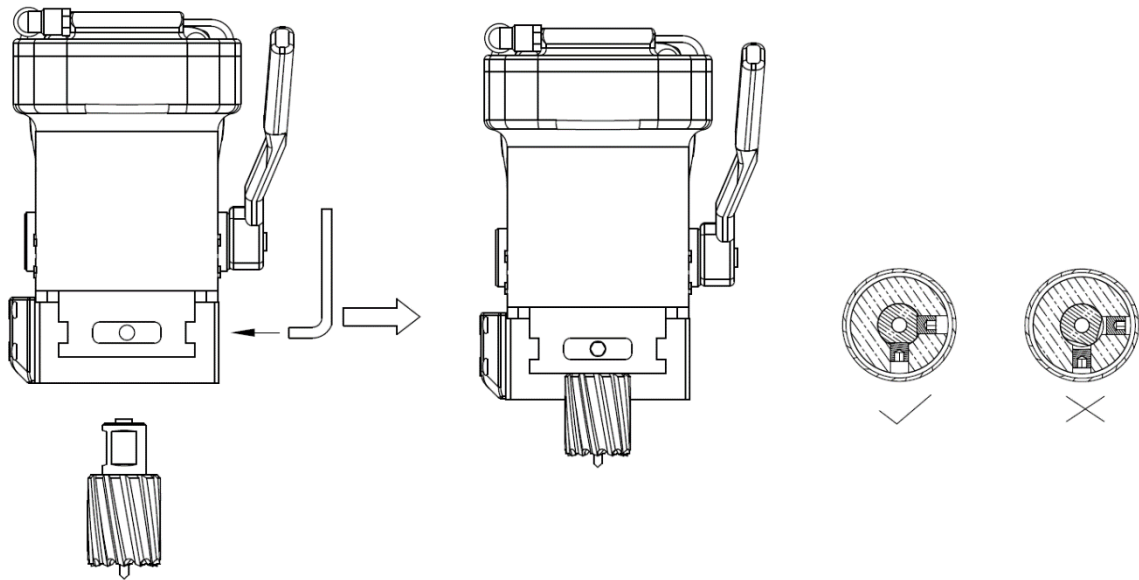

[image 5-2]

- Align the flat faces on the cutter shank with the screws in the tool holder;
 - Make sure the cutter shank is entered fully and correctly;
 - Tighten the screws with the provided 4 mm Allen key;
2. Precisely mark the center of the hole;
 3. Use the pilot pin to position the machine in the correct position, with the tip of the pilot pin to meet the marked center of the hole;
 4. Connect the machine, switch on the magnet and verify that the drill is in the right position and that the machine is pushed tight against the work piece;
 5. Put open the valve of your lubrication system to release the oil;
 6. Switch the motor on and allow it to run at the required speed;
 7. Start moving the ratchet feed handle towards the front of the machine, pushing down the output shaft and annular cutter;
 8. Apply a regular pressure while drilling. The drilling performance does not improve by putting more pressure on the machine. Too much pressure will overload the motor and your annular cutter will be worn sooner;
- A continuous, non-discoloured iron swarf is a sign of correct drilling speed and a well-cooled, sharp cutter. Let the cutter do the job and give it time to cut the metal!***
9. Adjust the oil supply when necessary;
 10. Apply less pressure when the drill cuts through the material. The slug will be pushed out of the cutter by the pilot pin;
 11. Move the ratchet feed handle back until the output shaft is in its highest position and switch off the motor unit;

12. Remove the burrs, metal chips and clean the cutter and surface without getting injuries;

13. To remove the annular cutter, loosen the screws in the tool holder with the provided 4 mm Allen key.

 **WARNING:** The cutter and metal slug can be sharp and very hot!

5.2 Twist drills

Only use 19.05 mm (3/4") Weldon shank twist drills. For fitment and removal, follow instructions as provided in paragraph 5.1 Annular cutters.

5.3 Machine taps

This machine is equipped with counter clockwise rotation and can therefore also be used for tapping. Due to the combination of the small dimensions of the machine, the 40 mm (1 9/16") stroke and the space required, tapping is only possible below magnet level.

Drill taps with Weldon 19.05 mm (3/4") shank

1. Fit the drill tap (EUROBOOR code EDT.x) into the spindle and fasten by tightening the screws with the provided Allen key;
2. Make sure the direction of rotation is set at clockwise (right = R);
3. Drill the required hole and tap simultaneously by moving the ratchet feed handle;
4. Switch off the motor and set the direction of rotation to counter clockwise (left = L);
5. Switch on the motor again, and guide the motor unit upwards with the ratchet feed handle to allow the drill tap to come completely out of the work piece.

Machine taps with Weldon 19.05 mm (3/4") tap holder

Use tap holders with a 19.05 mm (3/4") Weldon shank (EUROBOOR code TCM.x) in coordination with machine taps of the desired industry standard (DIN/ASA/JIS).

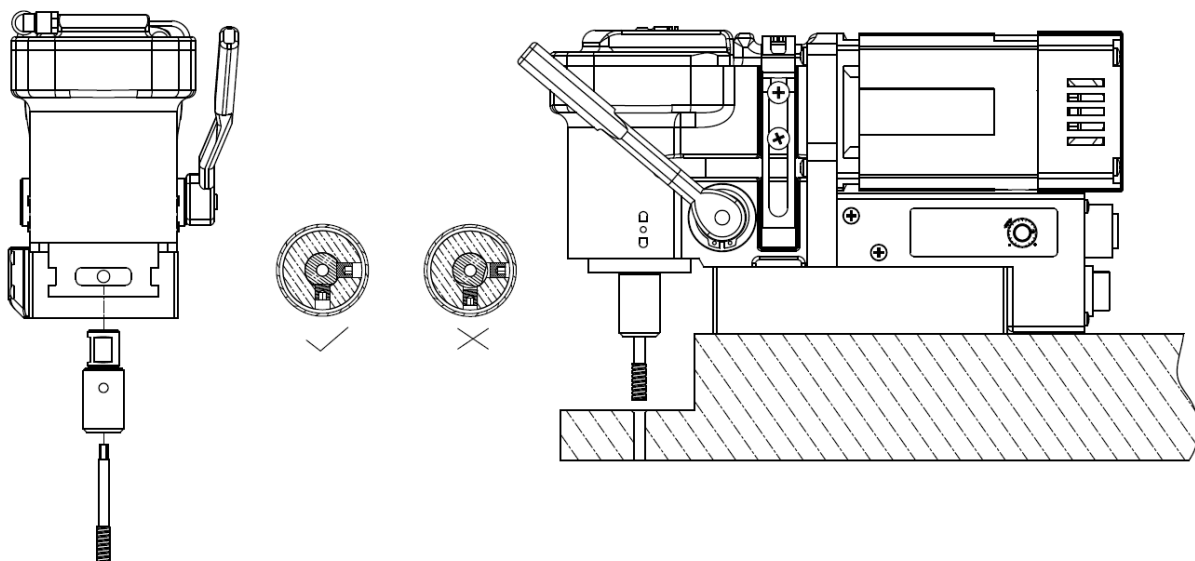

[image 5-3]

Proceed as follows:

1. Drill the hole for the tap on the recommended size;
2. Switch off the motor and change the cutter or drill for the tap holder and the machine tap;



WARNING: *Do not change the position of the machine!*

3. Install the machine tap into the tap holder and tighten the screws;
4. Fit the tap holder into the spindle and tighten the screws with the provided Allen key;
5. Make sure the shanks are entered fully and flats oriented correctly;
6. Select the lowest speed and set the rotation direction to clockwise (right = R);
7. To start tapping, switch on the motor and set the machine tap onto the drilled hole by moving the ratchet feed handle towards the front of the machine;
8. Gently guide the machine tap down with the ratchet feed handle without exerting too much force to prevent overload;
9. Switch off the motor when the desired through or blind hole has been achieved;
10. Set the rotation direction to counter clockwise (left = L);
11. Switch on the motor again and allow the machine tap to come completely out of the work piece



WARNING: *Do not let your tap push up the motor unit by itself!*

Make sure to properly lubricate while performing tapping work, see paragraph 5.1 Annular cutters.

5.4 Countersinks

The machine can also be used for reaming or countersinking. Use twist drills or separately available EUROBOOR countersinks with 19.05 mm (3/4") Weldon shank and a wider diameter range:

- SCE.25 for \varnothing 10 - 25 mm (3/8" - 1")
- SCE.40 for \varnothing 10 - 40 mm (3/8" - 1 9/16")

For installation follow the steps mentioned in previous paragraphs.

6. Maintenance

Your EUROBOOR magnetic drilling machine has been designed to operate over a long period of time. Continuous satisfactory operation depends upon proper tool care and regular cleaning.



CAUTION: To reduce the risk of injury, turn the machine off and disconnect machine from power source before installing and removing accessories, before adjusting or changing set-ups or when making repairs. Be sure the switch is in the OFF position. An accidental start-up can cause injury.

Just as every magnetic drilling machine with moving parts, your EUROBOOR magnetic drilling machine also needs regular maintenance service. A few recommendations follow :

Visually check the machine for damage

The machine must be checked before operating for any signs of damage that will affect the operation of the machine. Particular notice must be taken of the main cable, if the machine appears to be damaged it should not be used. Failure to do so may cause injury or death.

Cleaning

- Clean all dirt, dust, metal chips and burrs of your magnetic drilling machine;
- Blow dirt and dust out of the main housing with dry air as often as dirt is seen collecting in and around the air vents. Wear approved eye protection and an approved dust mask;
- Never use solvents or other harsh chemicals for cleaning the non-metallic parts of the tool. These chemicals may weaken the materials used in these parts. Use a cloth dampened only with water and mild soap. Never let any liquid get inside the tool; never immerse any part of the tool into a liquid.

Operation of the machine

The machines operation must be checked to ensure that all components are working correctly. Replace any defective parts immediately. This prevents properly functioning parts from being damaged.

Check magnetic base

Before every operation the magnetic base should be checked to make sure that the base is flat and there is no damage present. An uneven magnet base will cause the magnet to hold not as efficiently and may cause injury to the operator. When the machine is put out of use for a longer period, apply a small amount of machine oil to the underside of the magnetic base for rust protection. Clean the magnetic base again with next use.

Check gearbox grease

The gearbox grease should be checked and replaced at least once a year to ensure maximum lubrication and cooling, and thus the best performance and durability of the machine.

Carbon brush replacement

Schedule to replace the carbon brushes when the carbon brush LED indicator lights up. The remaining operating time depends on the use of the machine. When the carbon brushes are fully worn, the machine will shut-off automatically. Replace the carbon brushes to get it working again.

Check armature

This should be checked at least once a month to check if there are visual signs of damage to the body or to the commutator. Some signs of wear will be seen on the commutator over a period of time this is normal as this is the part that comes in contact with the brushes but any signs of abnormal damage means the part should be replaced.

Adjustment of output shaft

An essential requirement of the machine is that the output shaft can move in a smooth and controlled manner, free of lateral movement and vibration. When supplied new, the output shaft has already been adjusted for ideal movement. After some time, up and down movement may become a little loose, requiring adjustment. This can be done by tightening the grub screw at the front of the machine with supplied Allen key (size 3 mm), as seen on image below.

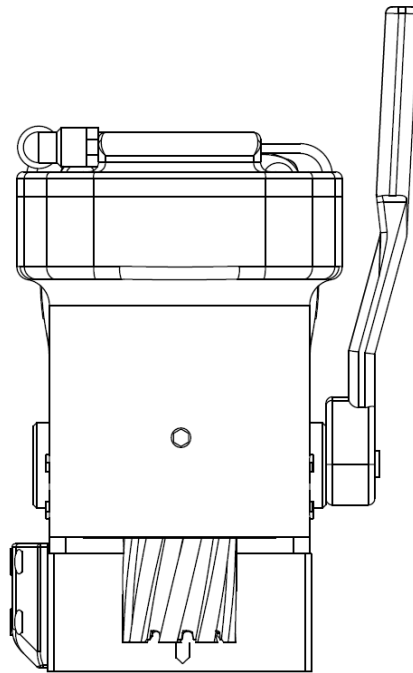

[image 6-1]

After adjustment the output shaft should be easy to move up and down, but should also stay at any height position. Do not overtighten the grub screw!

Repair, modification and inspection

Repair, modification and inspection of EUROBOOR Magnetic drilling machines must be done by EUROBOOR or an EUROBOOR authorised dealer. The spare parts list will be helpful if presented with the machine to the EUROBOOR dealer for service when requesting repair or other maintenance.

EUROBOOR machines are constantly being improved and modified to incorporate the latest technological advancements. Accordingly, some parts (i.e. part numbers and/or design) may be changed without prior notice. Also, due to EUROBOOR's continuing program of research and development, the specifications of machines are subject to change without prior notice.



WARNING: *Since accessories, other than those offered by EUROBOOR, have not been tested with this machine, use of such accessories with this tool could be hazardous. To reduce the risk of injury, only EUROBOOR recommended accessories should be used with this machine.*

Consult your dealer for further information on the appropriate accessories.

7. Trouble shooting

Magnet and motor do not function	<ul style="list-style-type: none"> - The magnet switch is not connected to the power supply - Damaged or defective wiring - Defective fuse - Defective magnet switch - Defective control unit - Defective power supply
Magnet does function, the motor does not work	<ul style="list-style-type: none"> - Damaged or defective wiring - Carbon brushes are stuck or worn out - Defective magnet switch - Defective On / Off switch - Defective control unit - Defective armature and/or field
Magnet does not function, the motor does	<ul style="list-style-type: none"> - Defective magnet - Defective wiring of magnet - Defective control unit
Annular cutters break quickly, holes are bigger than the annular cutter	<ul style="list-style-type: none"> - Clearance in the guide - Bent spindle - Shaft extending from the motor is bent - Bent pilot pin
Motor running roughly and/or seizing up	<ul style="list-style-type: none"> - Damaged output shaft - Worn transfer gear - Dirt in output shaft
Motor starts running when magnet switch is turned on	<ul style="list-style-type: none"> - Damage or defective relay in control unit
Motor making a rattling sound	<ul style="list-style-type: none"> - Gear ring (bottom of the armature) worn out - Gear(s) worn out - No grease in gearbox
Motor humming, big sparks and motor has no force	<ul style="list-style-type: none"> - Armature damaged (burned) - Field burned - Carbon brushes worn out
Motor does not start or fails	<ul style="list-style-type: none"> - Damaged or defective wiring - Dirt in sensor control unit - Defective or loose magnet on top of armature - Damaged or defective (sensor) control unit - Damage to armature or field coil - Damaged or defective carbon brushes
Guiding takes a great deal of effort	<ul style="list-style-type: none"> - Adjustment grub screw has been overtightened tight - Dirt between output shaft and gearbox housing - Dirt in height adjustment gear/rack assembly - Insufficient lubrication on outside of output shaft

Insufficient magnetic force	<ul style="list-style-type: none"> - Damaged or defective wiring - Bottom of magnet not clean and dry - Bottom of magnet not flat - Workpiece is not bare metal - Workpiece is not clean or flat - Workpiece is less than 6 mm (too thin) - Defective control unit - Defective magnet
Frame under voltage	<ul style="list-style-type: none"> - Damaged / defective wiring - Defective magnet - Motor seriously dirty
Fuse blows when magnet switch is turned on	<ul style="list-style-type: none"> - Damaged or defective wiring - Wrong value fuse - Defective magnet switch - Defective control unit - Defective magnet
Fuse blows when motor is started	<ul style="list-style-type: none"> - Damaged or defective wiring - Wrong value fuse - Motor running roughly - Defective armature and / or field - Carbon brushes worn out - Defective control unit

8. Exploded views & spare parts list

8.1 Exploded views

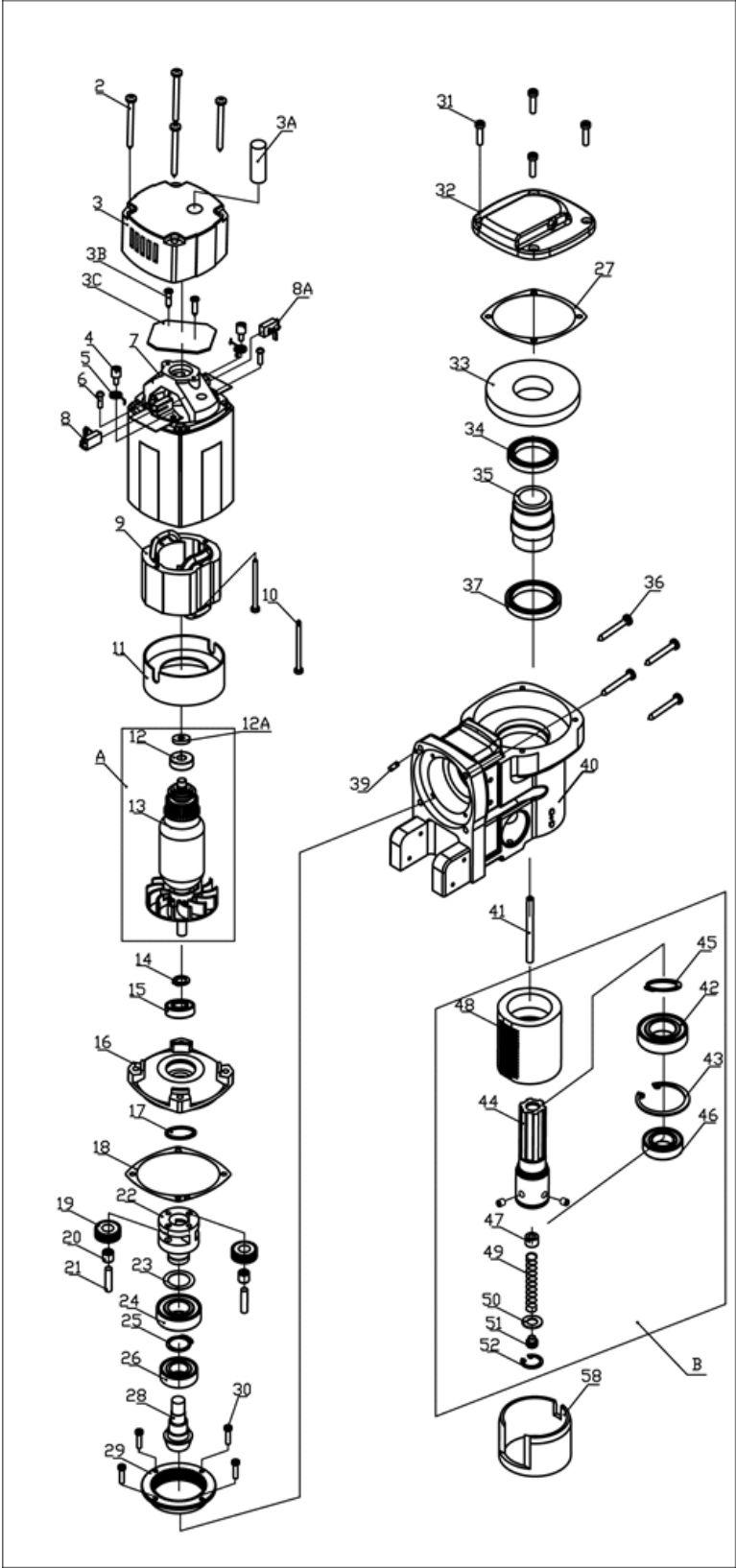

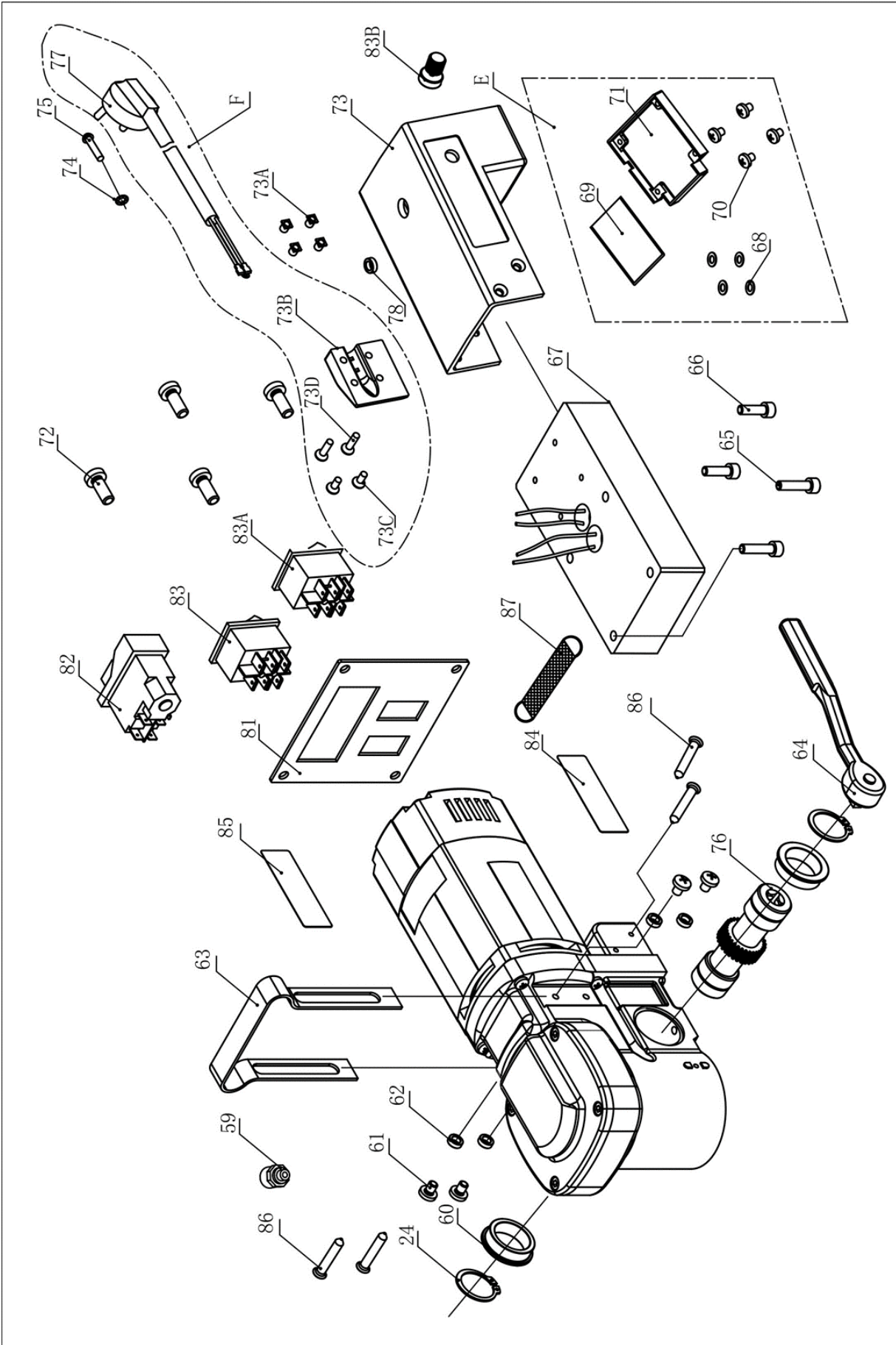

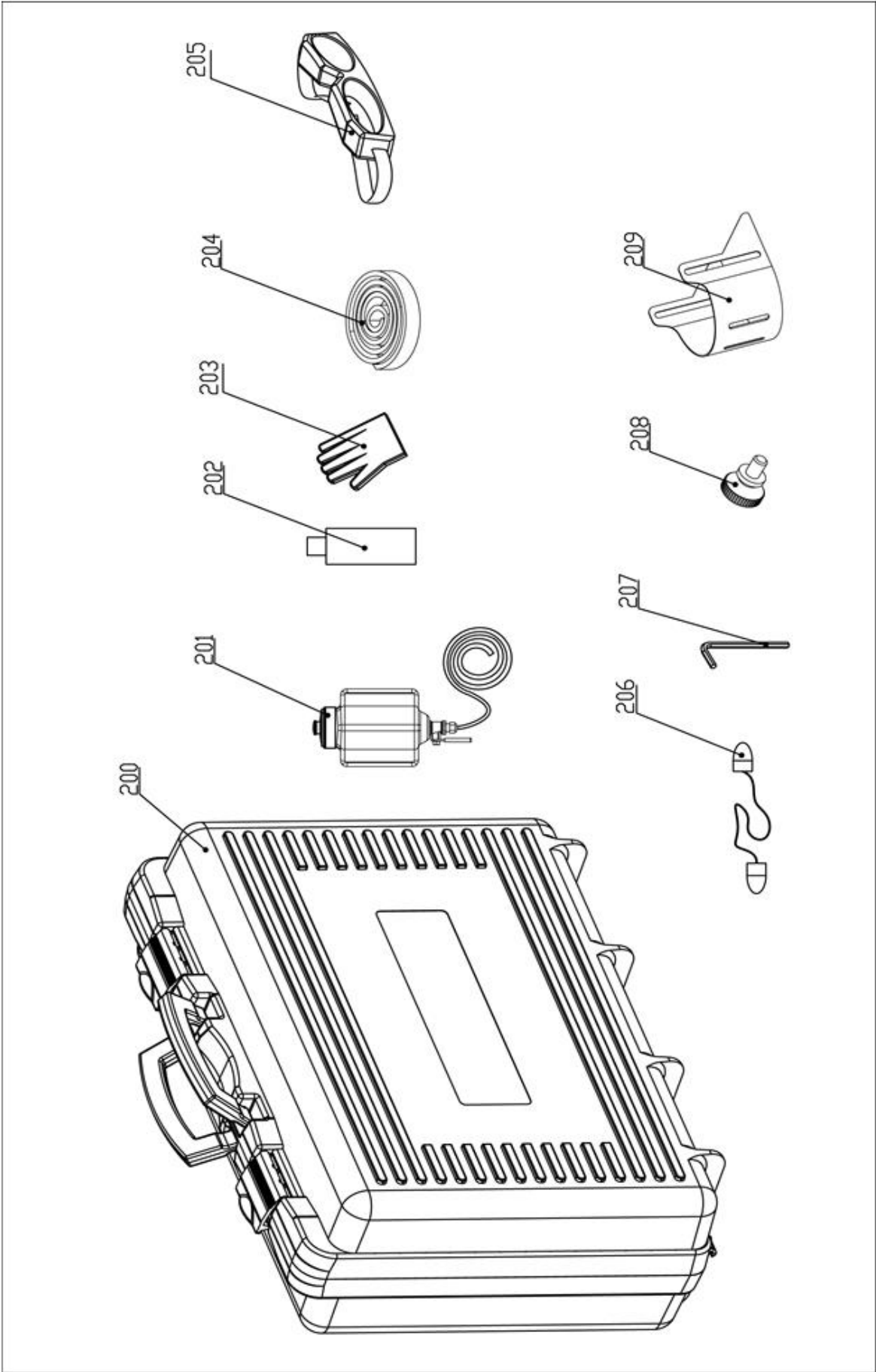

8.2 Spare parts list

No.	Part no.	Description	Qty
1			
2	036.0043	Torx screw M4.8 x 55	4
3	036.0111T	End cover	1
3A	050.0062	Light guide pin LG6040-4.5	1
3B	032.0116	Screw M4 x 16	2
3C	P036.0333 P036.0333A	Speed contr. unit 220V Speed contr. unit 110V	1
4	032.0136	Screw for spring	2
5	032.0141-1	Spring	2
6	020.0101	Panel screw BKVZ M4 x 8	2
7	036.1012T	Housing set	1
8	032.0146A 032.0146B	Carbon brush set 220V Carbon brush set 110V	1
8A	032.0146AUTO 032.0147AUTO	Carbon brush 220V Carbon brush 110V	1
9	036.0047T 036.0049T	Field 220V Field 110V	1
10	032.0156	Screw BK 4 x 55	2
11	032.0161	Baffle	1
12	036.1017T	Armature 110V incl. bearing	1
12A			
13	036.1018T	Armature 110V incl. bearing	
14	100.0571	Circlip 471 11 x 1	1
15	032.0171	Bearing 6001ZZ 12 x 28 x 8	1
16	036.0236	Inner gear plate	1
17	032.0166	Circlip 472/28/1.2	1
18	032.0125	Gasket	1
19	036.0038	Gear 0.8 x 28T	2
20	036.0008	Bearing HK0609	2
21	036.0010	Pin \varnothing 6 x 24	2
22	036.0129	Arbor	1
23	036.0131	Washer	1
24	030.0009	Bearing 6004 DDU	1
25	050.0076	Circlip \varnothing 20	1
26	032.0196	Bearing 6003 17 x 35 x 10	1
27	036.0138	Gasket	1
28	036.0025-01	Gear 2 x 11T	1
29	036.0035	Gear 0.8 X 62T	1
30	036.0007	Screw M4 x 8	4
31	036.0012	Screw M5 x 16	4
32	036.0002	Gear plate	1
33	036.0014	Gear 2 x 44T	1
34	036.0022	Bearing 61807 DDU	1
35	036.0009	Shaft	1

No.	Part no.	Description	Qty
36	036.0044	Torx screw M5 x 45	4
37	036.0023	Bearing 61808 DDU	1
39	050.0025	Pin 4 x 10	2
40	036.0001	Gear box	1
41	036.0017	Tube	1
42	036.2002T	Spindle assembly complete	1
43			
44			
45			
46			
47			
48			
49			
50			
51			
52			
57			
58	036.0011	Adapter ring	1
59	KSP.S	Coolant connector Quick angle plastic	1
60	036.0064	Adapter ring	2
61	036.0028	Screw M5 x 10	4
62	036.0029	Screw	4
63	036.0152	Handle	1
64	036.0026	Spanner	1
65	020.0156	Bolt M6 x 20	2
66	020.0146	Screw M6 x 25	2
67	036.1025 036.1025TA	Magnet 220V Magnet 110V	1
68	020.0017	Fuse 5 x 20 F2A	1
68	036.1008Z	Control unit	1
69			
70			
71			
71A			
72	055.0022	Screw M4 x 12	4
73	036.0003T	Cover	1
73A	020.0087	Rivet \varnothing 5	4
73B	036T.1016 (EU2)	Main cable cover	1
73C		Flat head screw M4 x 12	2
73D	036T.1016A (US1)	Flat head screw M4 x 16	2
77		Main cable 110V USA	1
74	040.0286F	Washer M4	1
75	036.0007	Screw M4 x 8	1
76	036.0065	Arm for capstan	1
81	036.0006T	Control panel plate	1

No.	Part no.	Description	Qty
82	030E.0091/Y	Motor switch 220V (5-pin) YELLOW	1
	030E.0092/Y	Motor switch 110V (5-pin) YELLOW	
83	020.0011/1	Magnet switch	1
83A	036.1009	Potentiometer	1
83B	036.0072	L/R switch	
84	036+.0015T	Front panel ECO.36+/T 220V	1
	036+.0015TA	Front panel ECO.36+/T 110V	
85	036+.0016T	Rear panel ECO.36+/T	1
86	036.0036	Screw M4 x 10	4

No.	Part no.	Description	Qty
87	036.0040	D-belt	1
88	020.0257	Capacitance	1
200	CAS.36	Case for ECO.36	1
201	036.2019	Coolant tank	1
202	IBO.0.2L	Bottle 0.2LTR	1
203	SAF.300	Protective gloves	1
204	036.0033	Safety belt	1
205	SAF.100	Safety goggles	1
206	SAF.200	Ear plugs	1
207	IMB.US3	Allen key 3.0 mm	1
207A	IMB.US4	Allen key 4.0 mm	1
208	036.0027	Screw	2
209	036.0111	Safety guard	1

8.3 Wiring diagram

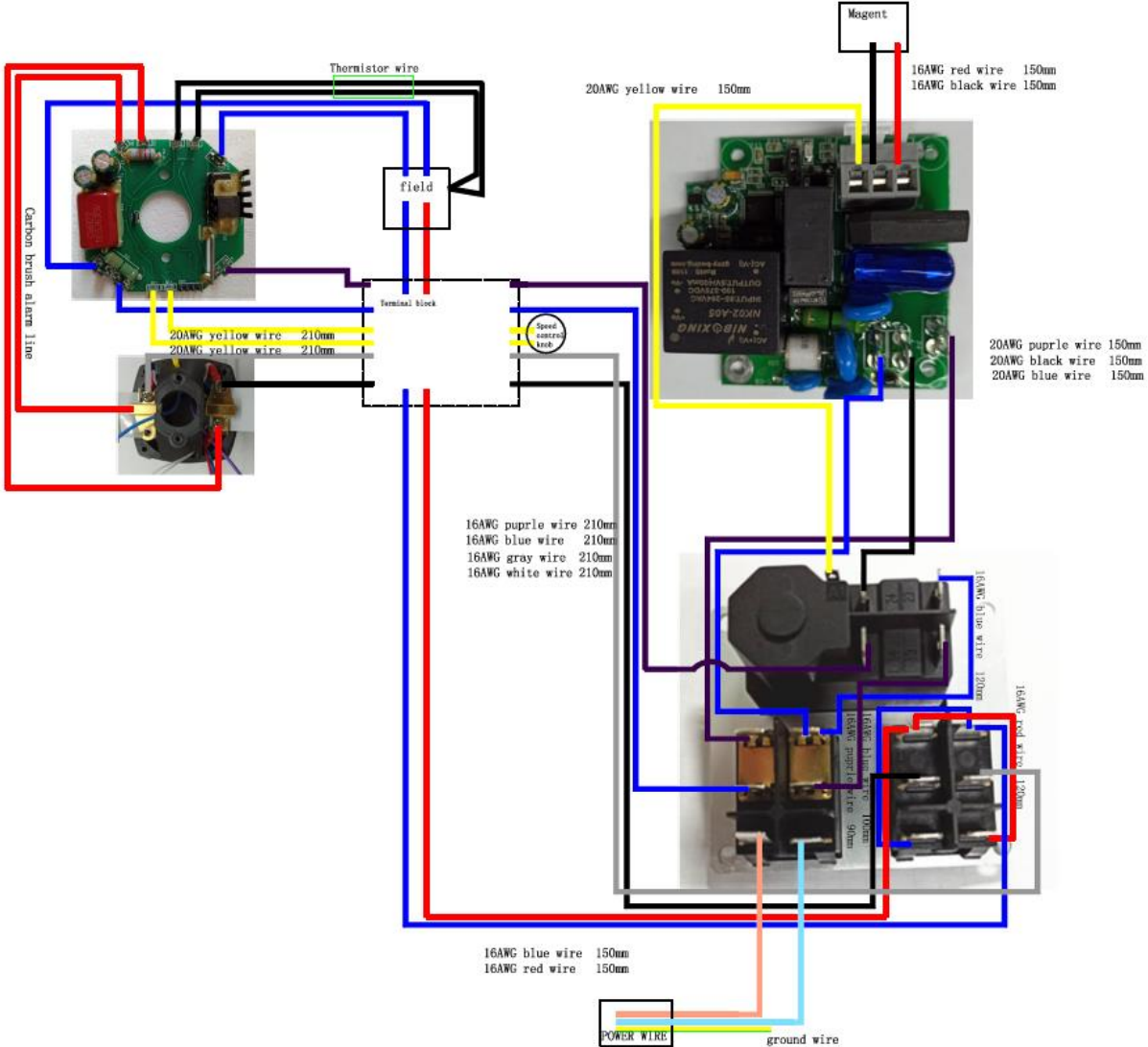

8.4 Warranty and service

Warranty

Euroboor B.V. warrants this magnetic drilling machine to be free of material defects and workmanship errors under normal use for a period of 12 months after date of purchase.

This 12 month period can be extended to 24 months in total by registering the product on our website: <https://euroboor.com/support/register/>.

Serial number:

Date of purchase:

**Don't forget to register your machine at:
<https://euroboor.com/support/register/>
[only when registered you benefit from extended warranty]**

Service

To maximise the lifetime of your EUROBOOR machine always use service and parts from an official EUROBOOR distribution channel. Whenever in need of such, always contact original point of sales or, if no longer existent, the distributor of EUROBOOR products in your country.